

Centre No.						Paper Reference						Surname	Initial(s)			
Candidate No.						5	3	8	4	H	/	1	3	H	Signature	

Paper Reference(s)

**5384H/13H**

# Edexcel GCSE

**Mathematics (Modular) – 2381**

Paper 13 (Non-Calculator)

## Higher Tier

Unit 3

Monday 7 June 2010 – Afternoon

Time: 1 hour 10 minutes

Examiner's use only

--	--	--

Team Leader's use only

--	--	--



**Materials required for examination**

Ruler graduated in centimetres and millimetres, protractor, compasses, pen, HB pencil, eraser.  
Tracing paper may be used.

**Items included with question papers**

Nil

**Instructions to Candidates**

In the boxes above, write your centre number, candidate number, your surname, initials and signature.

Check that you have the correct question paper.

Answer ALL the questions. Write your answers in the spaces provided in this question paper.

**You must NOT write on the formulae page.**

**Anything you write on the formulae page will gain NO credit.**

If you need more space to complete your answer to any question, use additional answer sheets.

**Information for Candidates**

The marks for individual questions and the parts of questions are shown in round brackets: e.g. (2).

There are 18 questions in this question paper. The total mark for this paper is 60.

There are 16 pages in this question paper. Any blank pages are indicated.

**Calculators must not be used.**

**Advice to Candidates**

Show all stages in any calculations.

Work steadily through the paper. Do not spend too long on one question.

If you cannot answer a question, leave it and attempt the next one.

Return at the end to those you have left out.

This publication may be reproduced only in accordance with Edexcel Limited copyright policy.  
©2010 Edexcel Limited.

Printer's Log. No.

**N36811A**

W850/R5384H/57570 6/6/3



*Turn over*

**edexcel**   
advancing learning, changing lives

## GCSE Mathematics

Formulae: Higher Tier

**You must not write on this formulae page.  
Anything you write on this formulae page will gain NO credit.**

**Volume of a prism** = area of cross section  $\times$  length

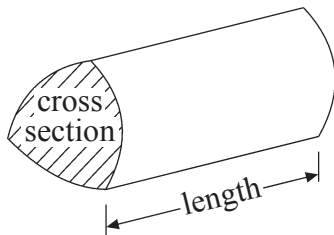

**Volume of sphere** =  $\frac{4}{3}\pi r^3$

**Surface area of sphere** =  $4\pi r^2$

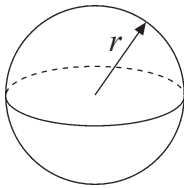

**Volume of cone** =  $\frac{1}{3}\pi r^2 h$

**Curved surface area of cone** =  $\pi r l$

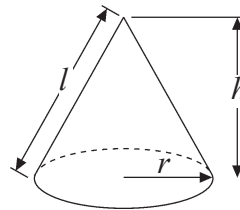

**In any triangle ABC**

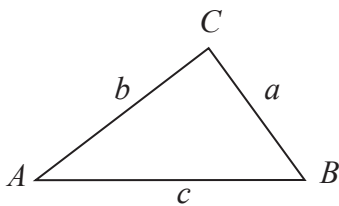

**The Quadratic Equation**

The solutions of  $ax^2 + bx + c = 0$

where  $a \neq 0$ , are given by

$$x = \frac{-b \pm \sqrt{b^2 - 4ac}}{2a}$$

**Sine Rule**  $\frac{a}{\sin A} = \frac{b}{\sin B} = \frac{c}{\sin C}$

**Cosine Rule**  $a^2 = b^2 + c^2 - 2bc \cos A$

**Area of triangle** =  $\frac{1}{2} ab \sin C$



**Answer ALL EIGHTEEN questions.**

**Write your answers in the spaces provided.**

**You must write down all stages in your working.**

**You must NOT use a calculator.**

1. There are 200 children in a school.  
120 of the children are boys.

What percentage of the children are boys?

..... %

**(Total 2 marks)**

**Q1**

2.  $B = 2k + 12$

$k = 5$

- (a) Work out the value of  $B$ .

$B = \dots\dots\dots$   
**(2)**

$T = 4w - 2$

$T = 22$

- (b) Work out the value of  $w$ .

$w = \dots\dots\dots$   
**(2)**

**(Total 4 marks)**

**Q2**



3.

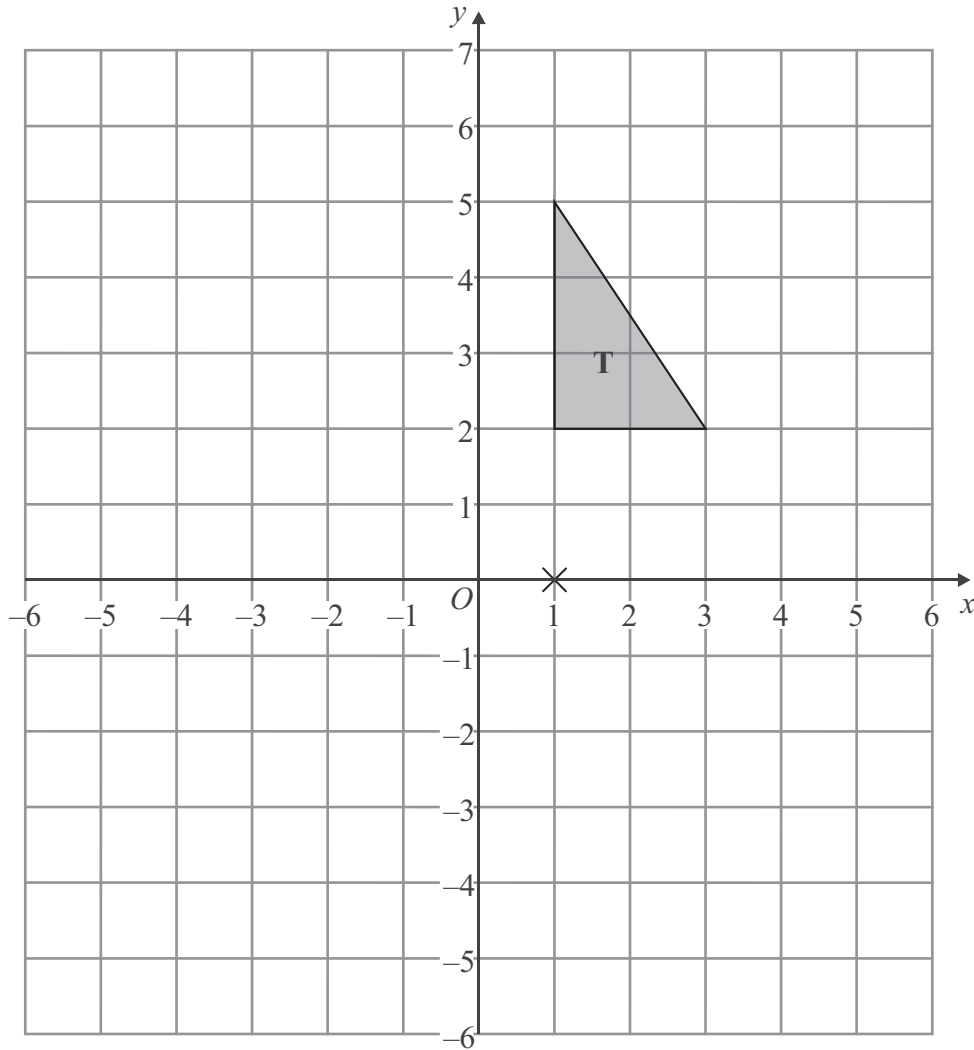

Triangle **T** has been drawn on the grid.

Rotate triangle **T**  $180^\circ$  about the point (1, 0).  
Label the new triangle **A**.

(Total 2 marks)

Q3



4.

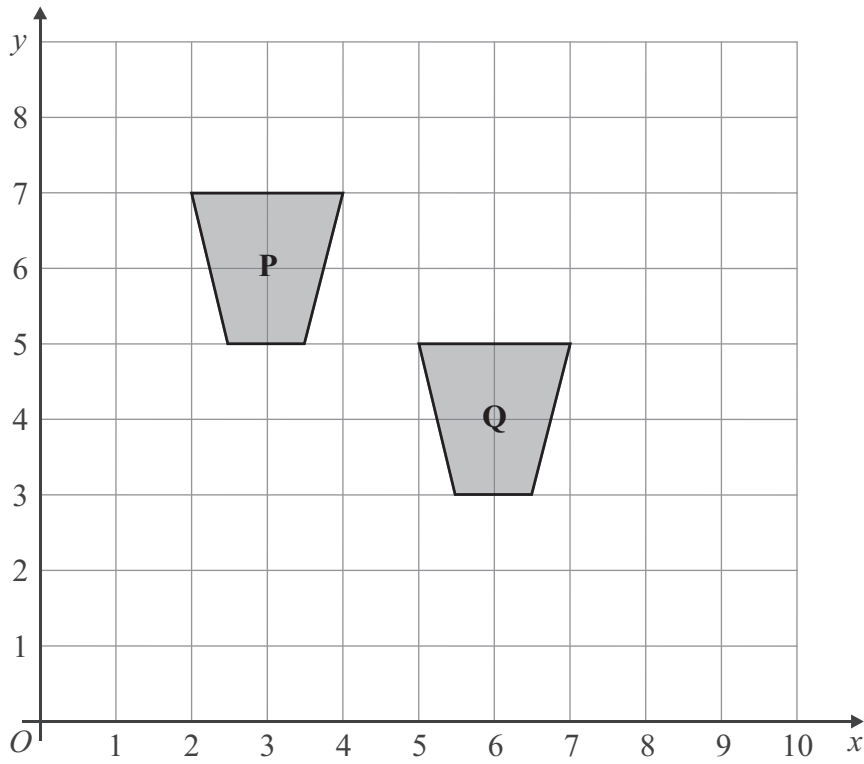

Describe fully the single transformation which maps shape **P** onto shape **Q**.

.....  
.....

(Total 2 marks)

Q4



5. Nigel travelled from his home to his friend's house 40 km away. He stayed at his friend's house for 30 minutes. Nigel then travelled home.

Here is part of the distance-time graph for Nigel's journey.

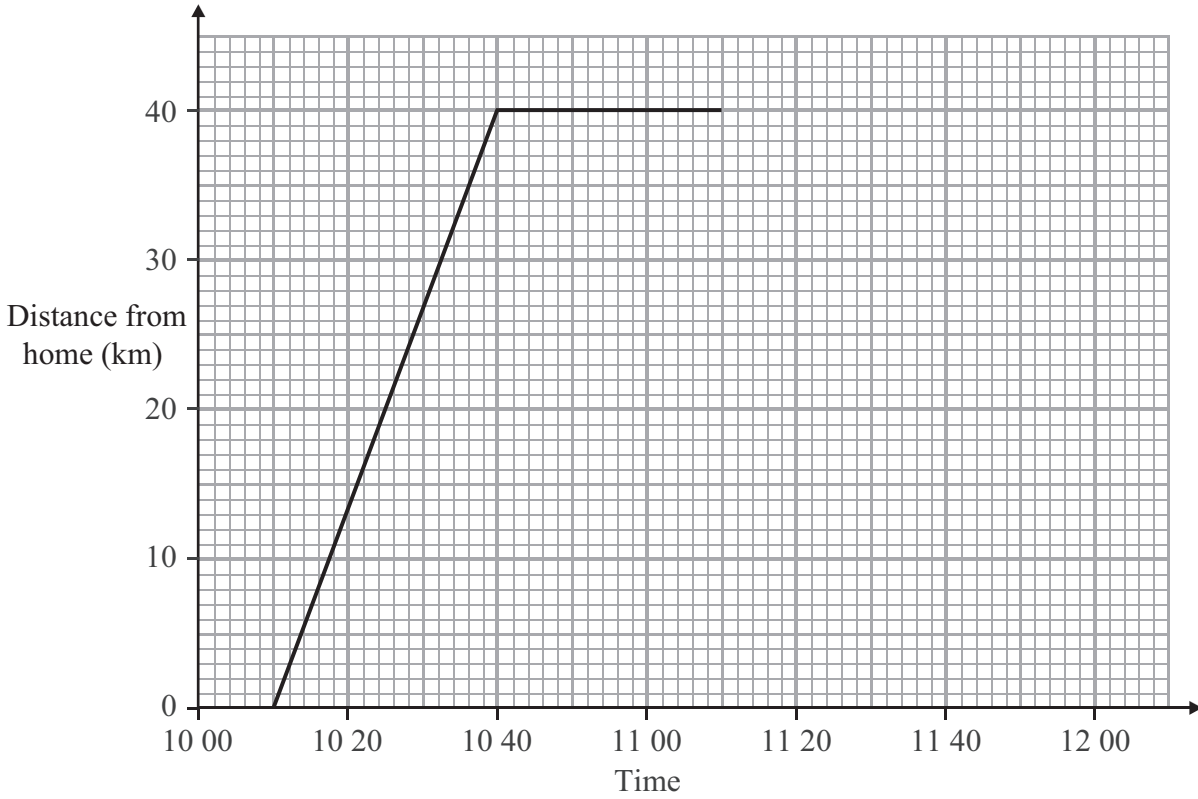

- (a) At what time did Nigel leave home?

..... (1)

- (b) How far was Nigel from home at 10 20?

..... km (1)

Nigel arrived home at 11 50

- (c) Complete the distance-time graph.

(1)

(Total 3 marks)

Q5



6. Here is a sketch of a cuboid.

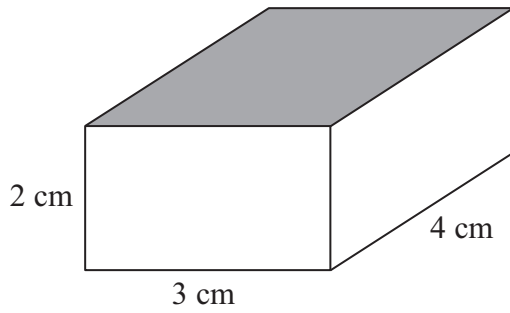
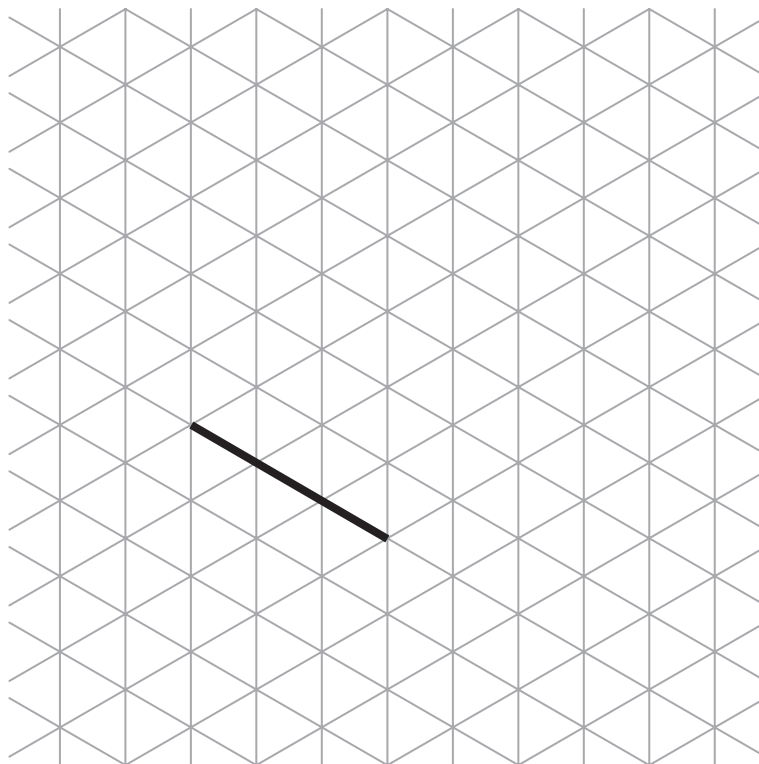

Diagram **NOT** accurately drawn

- (a) On the isometric grid below, make an accurate drawing of this cuboid. One edge has been drawn for you.



(2)

- (b) Work out the area of the top face of the cuboid.

..... cm<sup>2</sup>  
(2)

(Total 4 marks)

Q6



7.

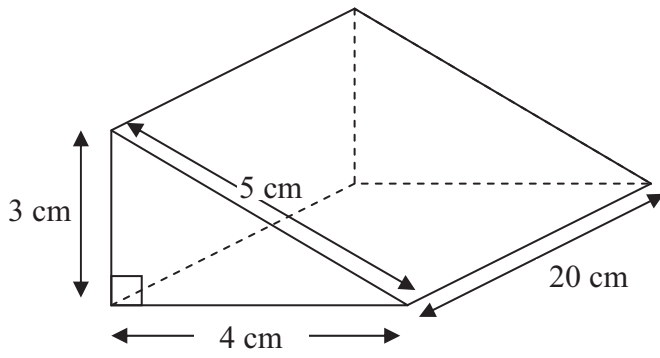

Diagram **NOT** accurately drawn

Work out the volume of the triangular prism.

..... cm<sup>3</sup>

**(Total 2 marks)**

Q7



8. There are 300 people in a cinema.

$\frac{1}{6}$  of the 300 people are boys.

$\frac{3}{10}$  of the 300 people are girls.

The rest of the people are adults.

Work out how many people are adults.

.....

Q8

(Total 4 marks)

9.

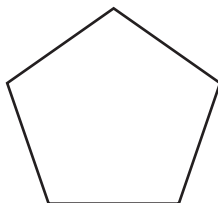

Diagram **NOT** accurately drawn

Work out the size of an exterior angle of a regular pentagon.

..... °

Q9

(Total 2 marks)



10. (a) Complete the table of values for  $y = x^2 + x - 3$

$x$	-4	-3	-2	-1	0	1	2
$y$	9		-1	-3			3

(2)

(b) On the grid below, draw the graph of  $y = x^2 + x - 3$  for values of  $x$  from -4 to 2

(2)

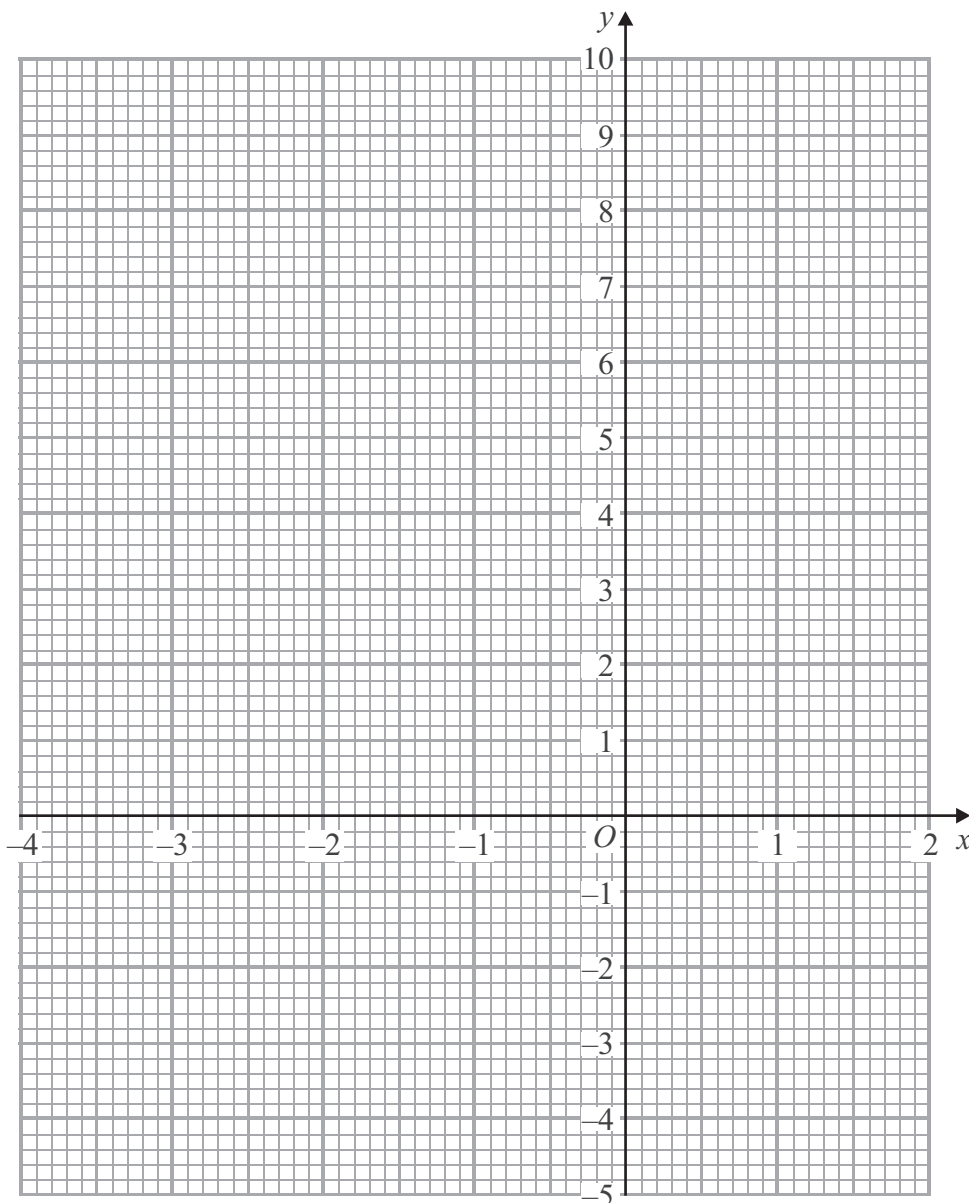

(c) Use your graph to find estimates for the solutions of  $x^2 + x - 3 = 0$

$x = \dots\dots\dots$

$x = \dots\dots\dots$

(1)

Q10

(Total 5 marks)

11. Here is a square.

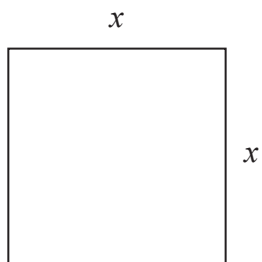

Diagram **NOT** accurately drawn

All the measurements are in centimetres.

The perimeter of the square is  $P$  cm.

(a) Express  $P$  in terms of  $x$ .

$P = \dots\dots\dots$

(1)

The area of the square is  $A$  cm<sup>2</sup>.

(b) Express  $A$  in terms of  $P$ .  
Give your answer in its simplest form.

$A = \dots\dots\dots$

(2)

Q11

(Total 3 marks)



12. Arwen buys a car for £4000  
The value of the car depreciates by 10% each year.

Work out the value of the car after two years.

£ .....

Q12

(Total 3 marks)

13. (a) Here are some expressions.

$a^3b$	$a^2(c + b)$	$4abc$	$ab + c^3$	$4\pi c^2$

The letters  $a$ ,  $b$ , and  $c$  represent lengths.  
 $\pi$  and 4 are numbers that have no dimension.

**Two** of the expressions could represent volumes.  
Tick the boxes (✓) underneath these two expressions.

(2)

The volume of this cube is  $8 \text{ m}^3$ .

- (b) Change  $8 \text{ m}^3$  into  $\text{cm}^3$ .

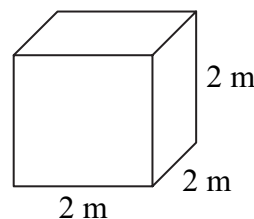

Diagram **NOT** accurately drawn

.....  $\text{cm}^3$   
(2)

Q13

(Total 4 marks)



14. Solve the simultaneous equations

$$\begin{aligned} 3x + 2y &= 8 \\ 2x + 5y &= -2 \end{aligned}$$

$x = \dots\dots\dots$

$y = \dots\dots\dots$

(Total 4 marks)

Q14

15. A straight line passes through (0, -2) and (3, 10).

Find the equation of the straight line.

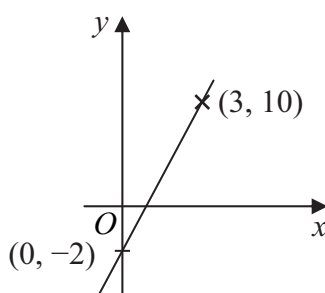

Diagram **NOT** accurately drawn

.....

(Total 3 marks)

Q15



16. Find the value of

(i)  $6^0$

.....

(ii)  $64^{\frac{1}{2}}$

.....

(iii)  $\left(\frac{27}{8}\right)^{\frac{2}{3}}$

.....

**(Total 4 marks)**

**Q16**

17. Solve  $x^2 = 4x + 12$

.....

**(Total 4 marks)**

**Q17**



18.

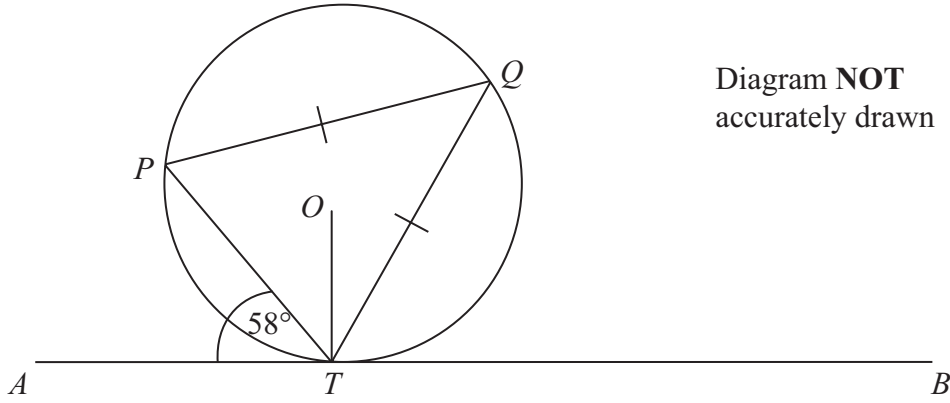

$P$ ,  $Q$  and  $T$  are points on the circumference of a circle, centre  $O$ .  
The line  $ATB$  is the tangent at  $T$  to the circle.

$PQ = TQ$ .  
Angle  $ATP = 58^\circ$ .

Calculate the size of angle  $OTQ$ .  
Give a reason for each stage in your working.

.....<sup>o</sup>

(Total 5 marks)

Q18

TOTAL FOR PAPER: 60 MARKS

END



**BLANK PAGE**

